



**PROFESSIONAL
THINKING**

PRODUCT SHEET EKF 423 U P

TECNOEKA SRL - VIA MARCO POLO, 11 - 35010 BORGORICCO - PADOVA - ITALY - TEL. +39 049 5791479 +39 049 9300344 - FAX +39 049 5794387 - E-MAIL: INFO@TECNOEKA.COM - WWW.TECNOEKA.COM - WWW.TECNOEKA.RU

EKF 423 U P - ELECTRIC CONVECTION OVEN WITH HUMIDIFICATION 4 TRAYS (429x345 mm)

EKA EASY LINE

BAKING



Thanks to the system of indirect humidification this oven allows you to make all your preparations more flavorful, tasty and fragrant.

Ideal for small eateries, bars and small bakeries that have to deal with tight spaces.

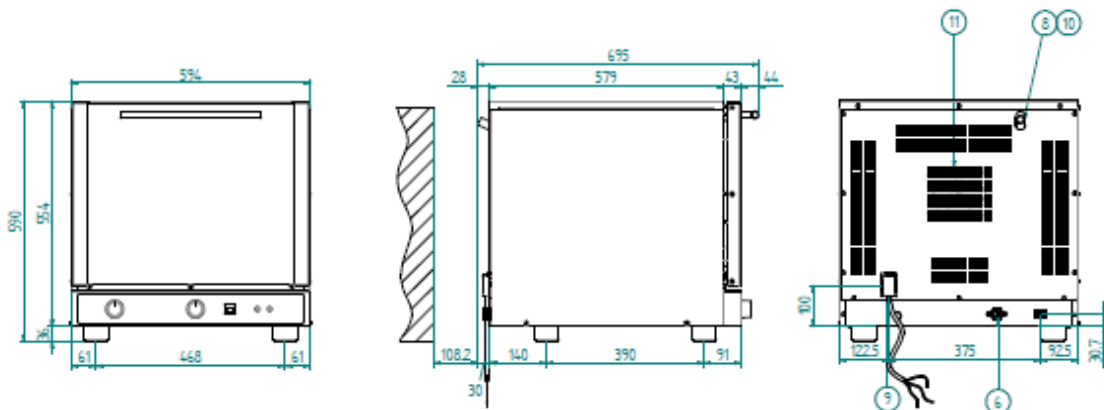

LEGEND

1	USB PORT	11	DON'T CLOG UP VENTILATION OPENINGS
2	SERIAL PORT	12	WATER INLET MAX. 200 kPa
3	PLUG FOR CORE PROBE	13	SOFTENED WATER INLET MAX 200 kPa
4	WATER OUTLET TUBE	14	BOILER CLEANING INLET
5	WASHING WATER INLET	15	DON'T OPEN CAP WHILE WORKING
6	SOFTENED WATER INLET	16	GAS INLET THREADED JOINT 3/4"
7	WATER INLET	17	POWER SUPPLY TO TOP OVEN
8	STEAM OUTLET	18	PRE-CARVED HOLE FOR BOTTOM OVEN POWER SUPPLY
9	ELECTRIC CABLE FIXER	19	STEAM SUCTION PIPE
10	CAUTION! HOT SURFACE		





**PROFESSIONAL
THINKING**

PRODUCT SHEET EKF 423 U P

TECNOEKA SRL - VIA MARCO POLO, 11 - 35010 BORGORICCO - PADOVA - ITALY - TEL. +39 049 5791479 +39 049 9300344 - FAX +39 049 5794387 - E-MAIL: INFO@TECNOEKA.COM - WWW.TECNOEKA.COM - WWW.TECNOEKA.RU

DIMENSIONAL FEATURES				FUNCTIONAL FEATURES	
DIMENSIONS	W	D	H	POWER	ELECTRICITY
OVEN DIMENSIONS (mm)	590	695	590	CAPACITY	N° 4 TRAYS (429x345 mm)
CARDBOARD BOX DIMENSIONS WITH PALLET (WxDxH mm)	680	760	600	TYPE OF COOKING	VENTILATED
OVEN DIMENSIONS (inches)	23,22	27,36	23,22	HUMIDIFICATION (see legend)	INDIRECT WITH BUTTON
CARDBOARD BOX DIMENSIONS WITH PALLET (inches)	26,77	29,92	23,62	COOKING CHAMBER	AISI 430 STAINLESS STEEL
OVEN WEIGHT (kg)	33,2			WATER OUTLET	/
PACKED OVEN WEIGHT (kg)	38,2			STEAM OUTLET	DIRECT
OVEN WEIGHT (lbs)	73,19			TEMPERATURE	50 + 300°C
PACKED OVEN WEIGHT (lbs)	84,21			TEMPERATURE CONTROL	THERMOSTAT
DISTANCE BETWEEN RACK RAILS (mm)	74			CONTROL PANEL	ELECTROMECHANIC – LOWER SIDE
FAN DIMENSION (mm)	Ø 150 - NR. 6 BLADES			N° OF PROGRAMS	/
CENTER-TO-CENTER DISTANCE BETWEEN FEET (mm)	468			PROGRAMMABLE COOKING STEPS	/
ELECTRICAL FEATURES				PRE-HEATING TEMPERATURE	/
				PRE-HEATING FUNCTION	/
POWER SUPPLY (kW)	2,8			DOOR	TILT DOOR
FREQUENCY (Hz)	50/60				INSPECTIONABLE GLASS
VOLTAGE (Volt)	AC 220/230			MODULARITY	AVAILABLE
N° OF MOTORS	1 UNIDIRECTIONAL			FEET	NOT ADJUSTABLE
RPM	2250			EQUIPMENT	
N° OF RESISTORS	CIRC.	1 pcs	2,7 kW	LATERAL SUPPORTS	1RIGHT + 1LEFT
	TOP+GRILL	/	/	ALUMINIUM TRAYS (429x345 mm)	4 pcs
	SOLE	/	/	CABLE	SINGLE-PHASE [3G 1,5] - L=1600 mm
BOILER	/			OPTIONAL	
LIMIT CONTROL	BIPOLAR WITH MANUAL RESET				
PROTECTION AGAINST WATER	/			AISI 430 ADAPTER KIT 2/3 GN (354x325 mm)	COD. KPG23
LIGHTING	NR. 1 INCANDESCENT LIGHT BULB (IN THE COOKING CHAMBER)			ALUMINIUM TRAY (429x345x9 mm)	COD. KV7
PLUS				HORIZONTAL CHROMED GRID (435x340 mm)	COD.KG7
STAINLESS STEEL COOKING CHAMBER				AISI 304 HORIZONTAL CHROMED GRID (435x340 mm)	COD.KG7X
DOOR OF THE OVEN WITH INSPECTIONABLE GLASS				TABLE	COD. EKT 423 – COD. EKTR 423 – COD. EKTS 423 – COD. EKTRS 423
EMBEDDED GASKET				PROOFER	COD. EKL 823
				OPTIONAL PACKAGING	COD. 01300731 CAGE COD. 01300280 PALLET (800x1200x118 mm)

LEGEND

HUMIDIFICATION



Water is filled in a drip box behind the air conveyor grid.
Sort of activation: with button or with knob.
Ideal for recipes that need humidity (for example roast meat).